

File		
RTD2871 Demo Board		
Size	Document Number	Rev
Customer	CHIP-PWR	1.0
Date:	Friday, March 01, 2019	Sheet 4 of 30

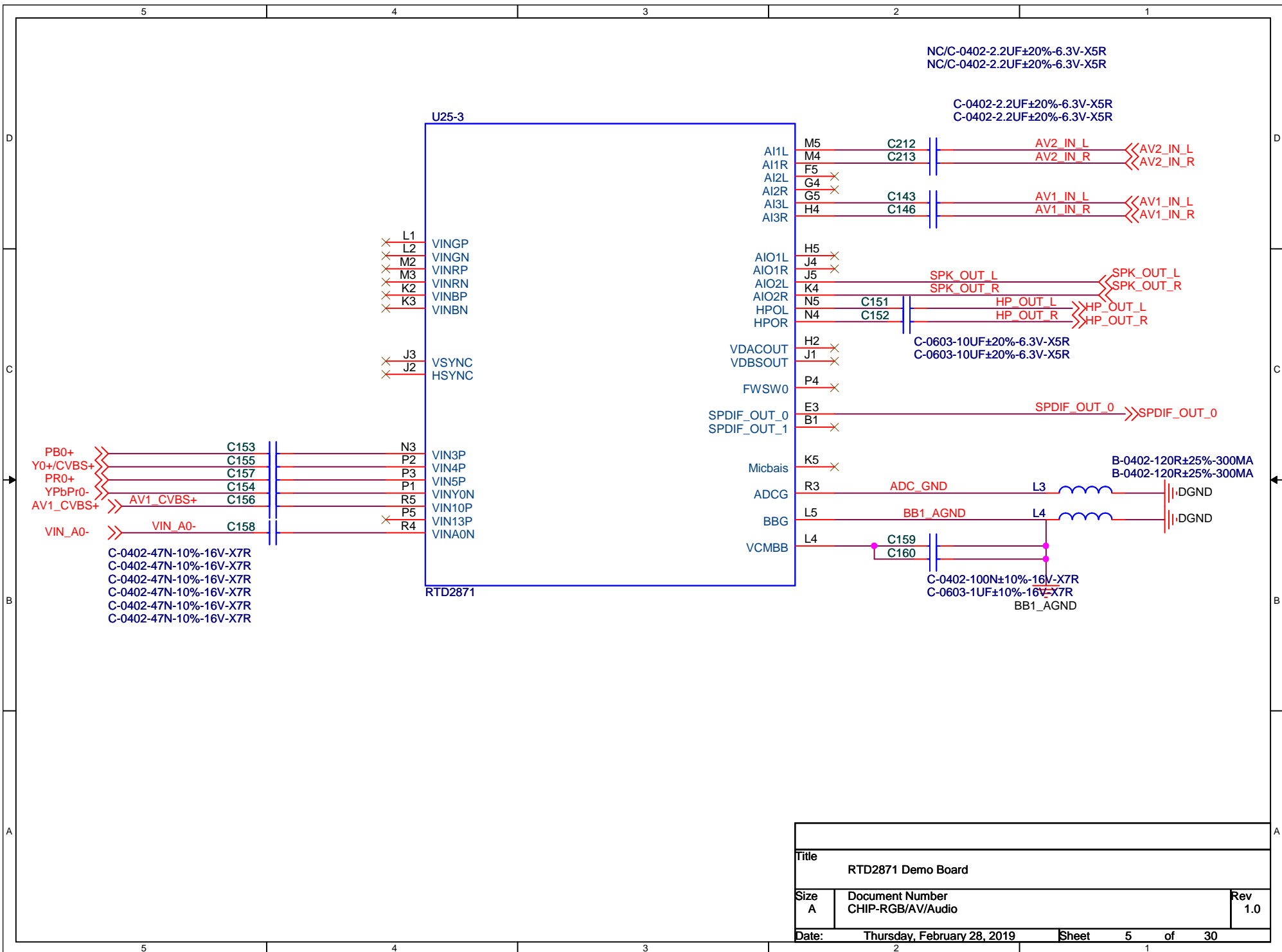

Title		
RTD2871 Demo Board		
Size	Document Number	Rev
A	CHIP-RGB/AV/Audio	1.0
Date:	Thursday, February 28, 2019	Sheet 5 of 30

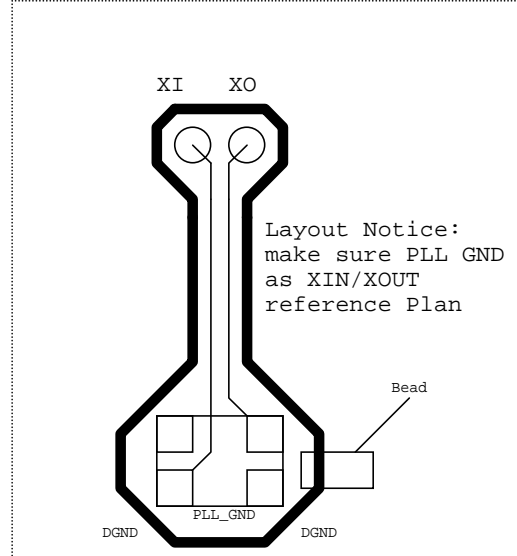
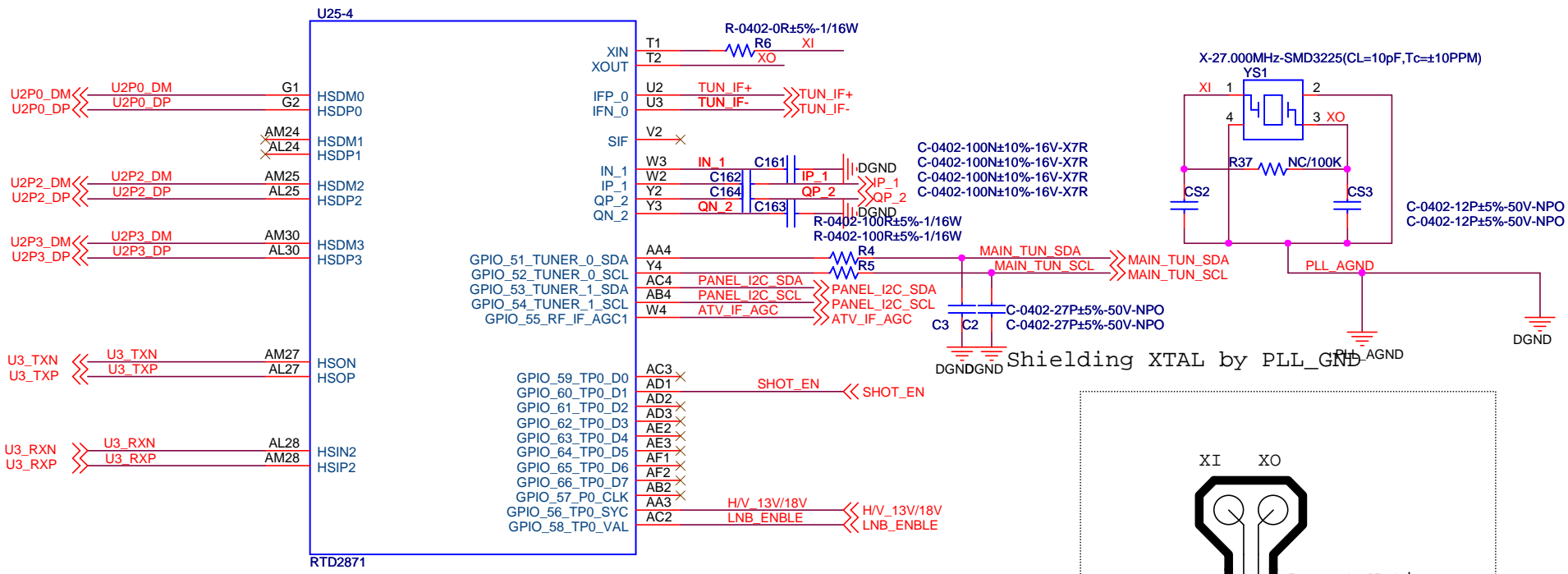

Title		
RTD2871 Demo Board		
Size	Document Number	Rev
A4	CHIP-USB/IFD	
Date:	Thursday, February 28, 2019	Sheet 6 of 30

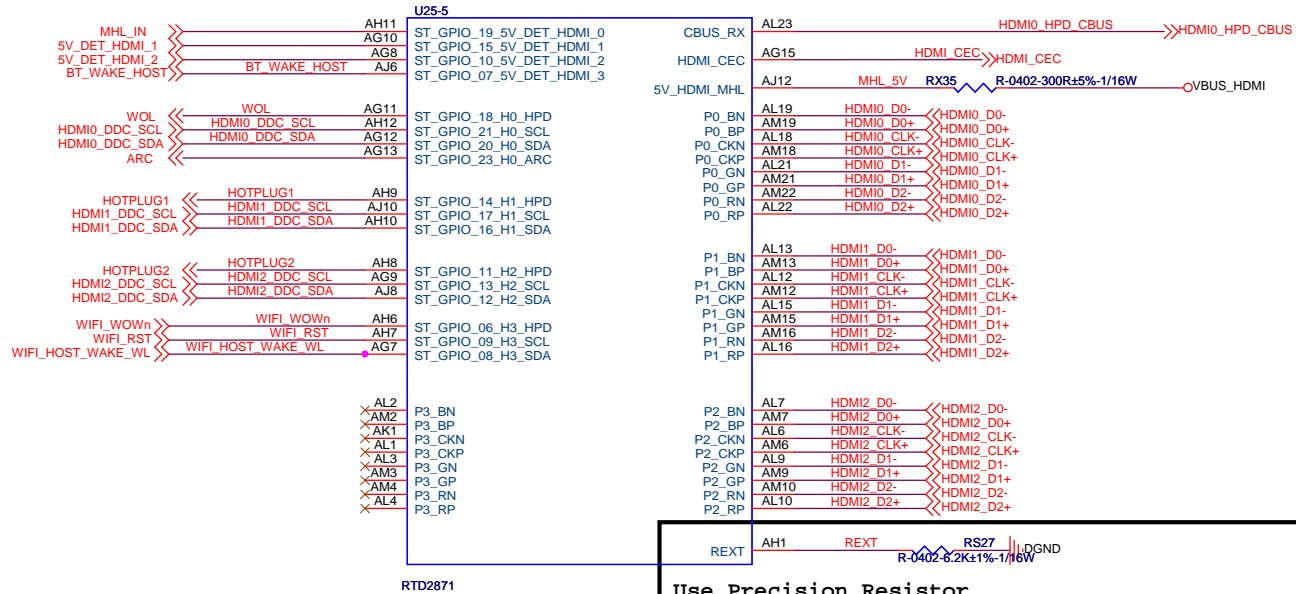

Use Precision Resistor
6.2K ohm close to the SOC and GNDshielding the Ball AJ1 trace.

Title		
RTD2871 Demo Board		
Size	Document Number	Rev
B	CHIP-HDMI	
Date:	Thursday, February 28, 2019	Sheet 7 of 30

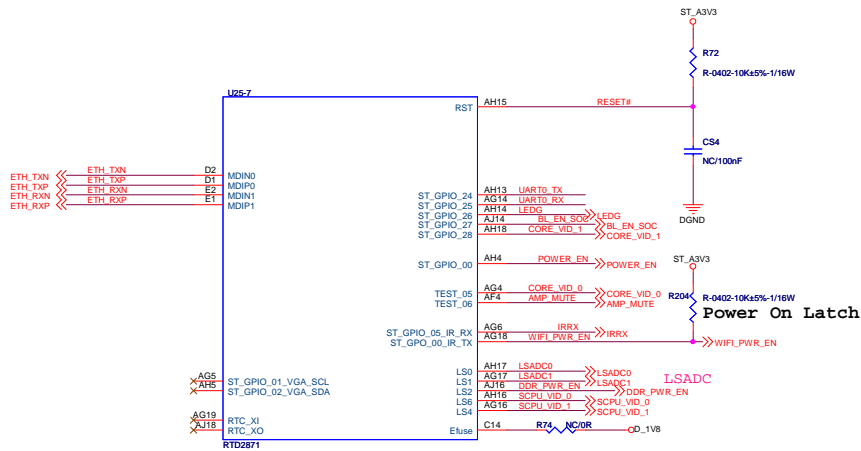
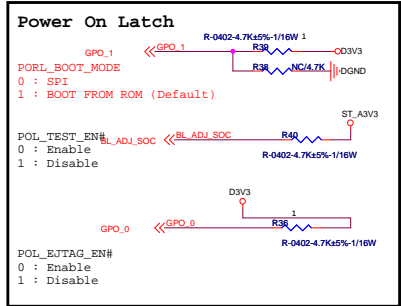
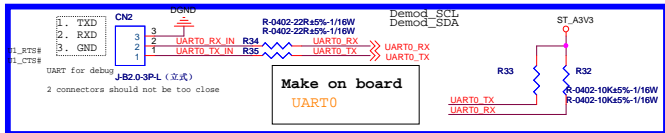

Title	RTD2871 Demo Board	
Size	Document Number	Rev
C	CHP-Standby	
Date	Thursday, February 28, 2019	Sheet 9 of 30

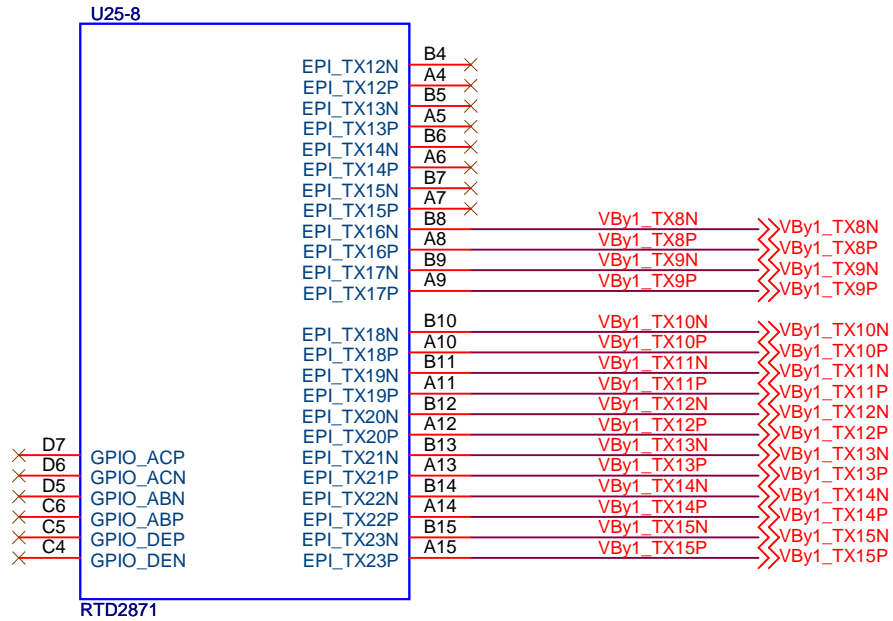

Title		
RTD2871 Demo Board		
Size	Document Number	Rev
A	CHIP-DISPLAY	
Date:	Thursday, February 28, 2019	Sheet 10 of 30

CVBS+Audio In

AV1_CVBS+
 VIN_A0
 AV1_IN_L
 AV1_IN_R

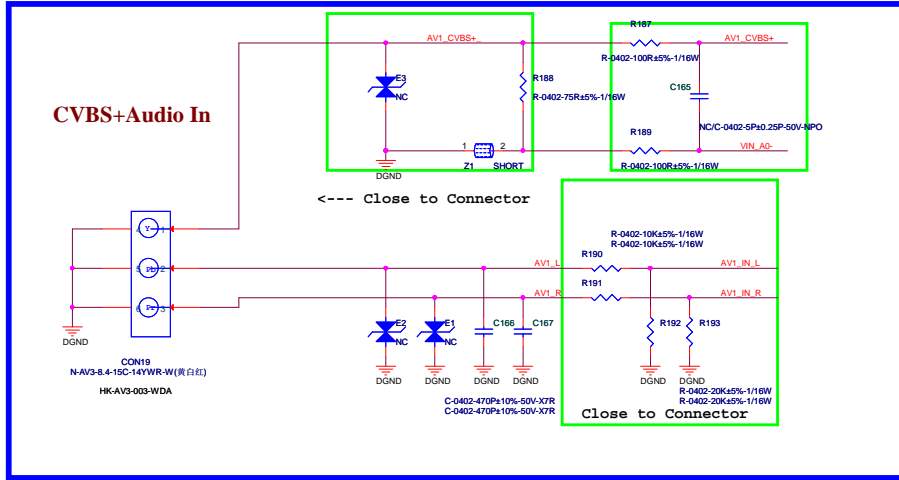

Title		
proj 009G L182CL1H		
Size	Document Number	Rev
C	AWAUD_IN	1.0
Date:	Thursday, February 28, 2019	Sheet 12 of 30

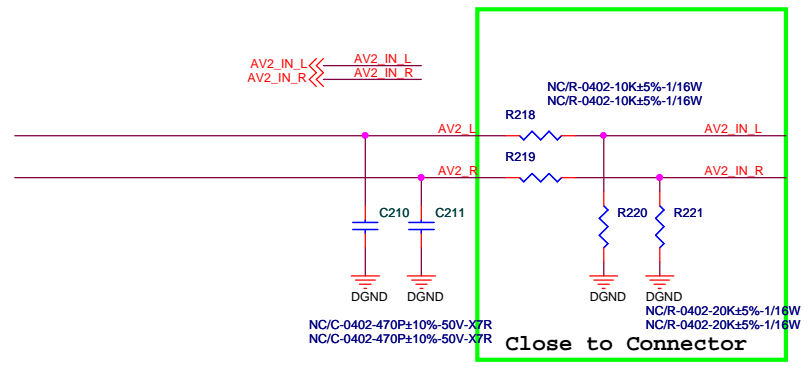
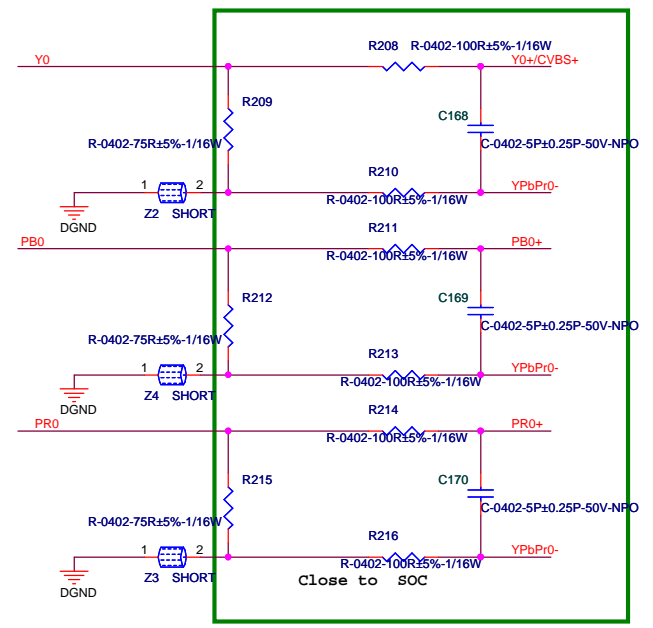
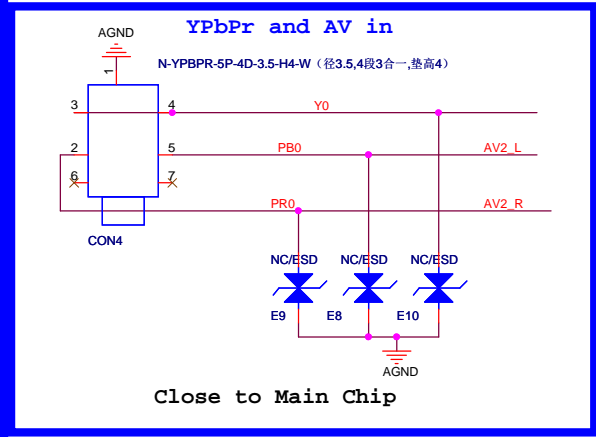

Title			<Title>
Size	Document Number	Rev	
B	<Doc>	<Rev Code>	
Date:	Thursday, February 28, 2019	Sheet	14 of 30

HDMI 1.4 ARC Fun.

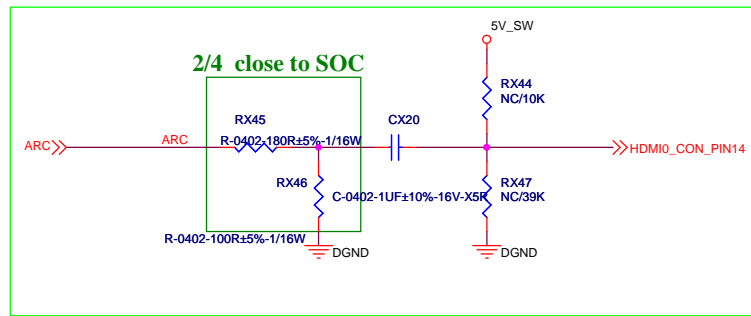

SPDIF_O one signal for two ball out

SPDIF OUT

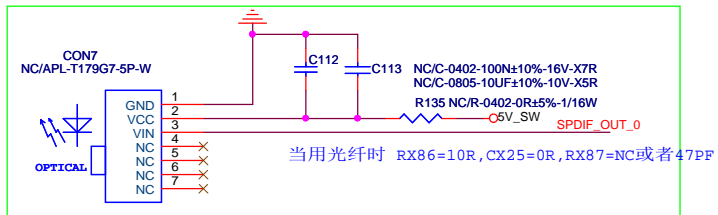
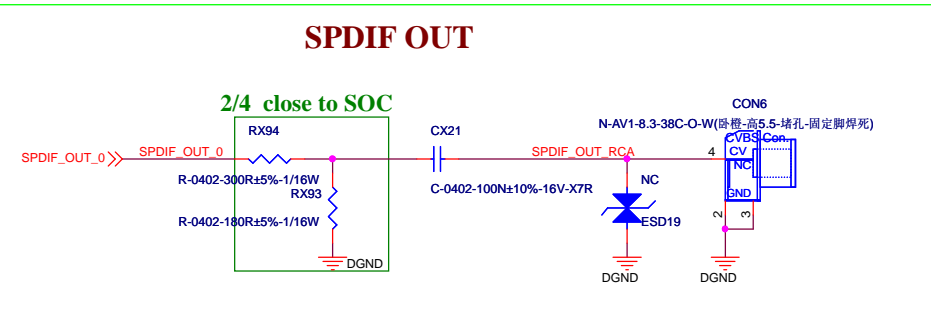

当用光纤时 RX86=10R, CX25=0R, RX87=NC或者47PF

Title		
RTD2871 Demo Board		
Size	Document Number	Rev
B	CHIP-SPDIF OUT	1.0
Date:	Thursday, February 28, 2019	Sheet 15 of 30

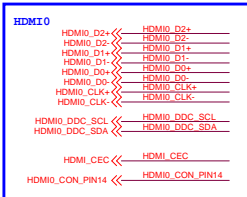

Mark on board
HDMI3

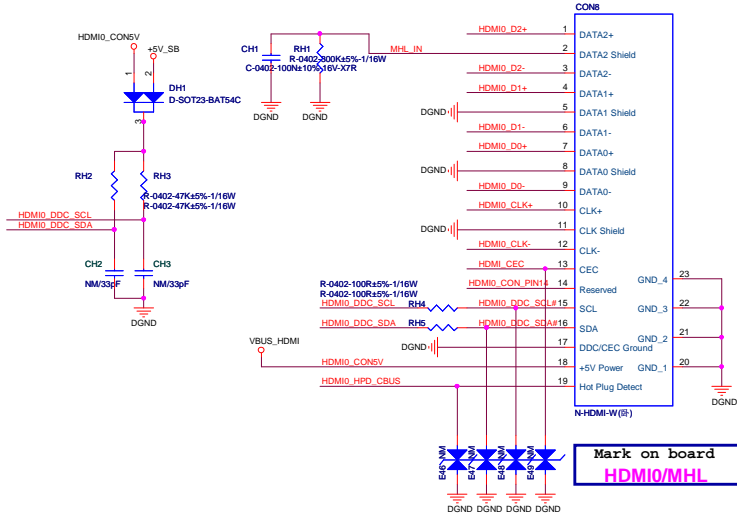
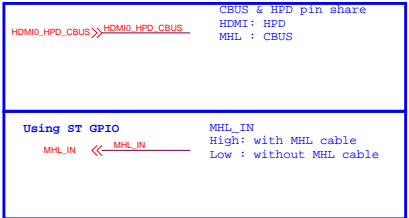

MHL Impedence (D0+/D0-)
Differential mode = 100R ± 15%
Common mode = 30R ± 6R

2-Layer PCB

GND	4mil	D0+	4mil	GND	4mil	D0-	4mil	GND
>10mil		12mil		5mil		12mil		>10mil

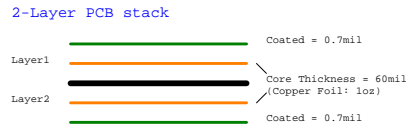

4-Layer PCB

GND	8mil	D0+	7mil	D0-	8mil	GND		
>10mil		5mil		5mil		>10mil		

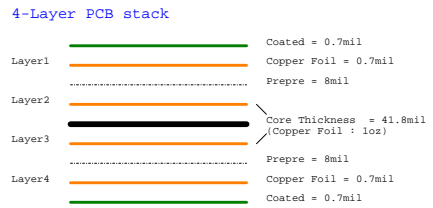

Title		RTD2871 Demo Board	
Size	Document Number	Rev	
C	HDMI0/MHL	1.0	
Date:	Thursday, February 28, 2019	Sheet	16 of 30

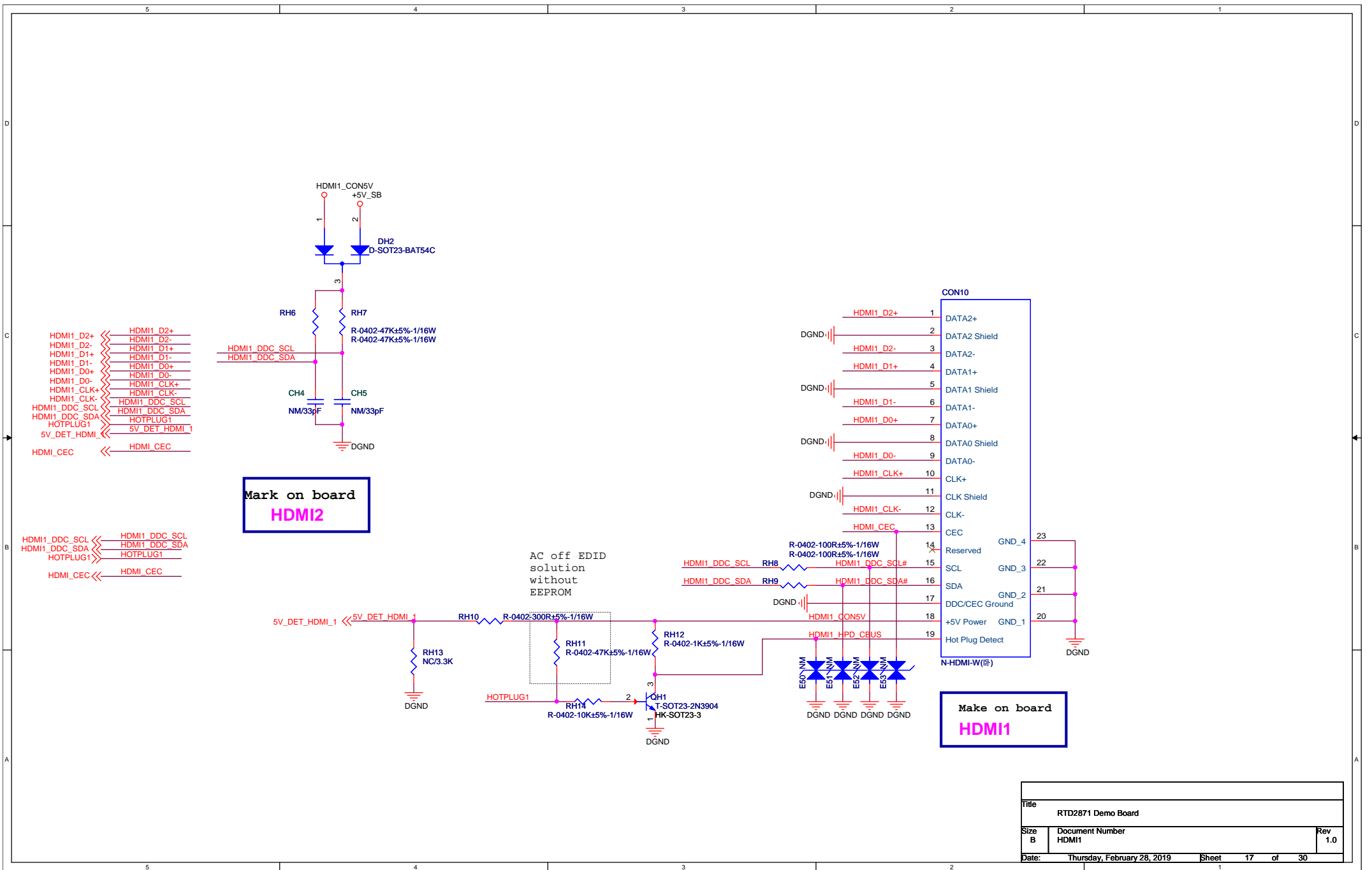

Title		
RTD2871 Demo Board		
Size	Document Number	Rev
B	HDMI1	1.0
Date:	Thursday, February 28, 2019	Sheet 17 of 30

HDMI 2

HDMI2_D2+ << HDMI2_D2+
 HDMI2_D2- << HDMI2_D2-
 HDMI2_D1+ << HDMI2_D1+
 HDMI2_D1- << HDMI2_D1-
 HDMI2_D0+ << HDMI2_D0+
 HDMI2_D0- << HDMI2_D0-
 HDMI2_CLK+ << HDMI2_CLK+
 HDMI2_CLK- << HDMI2_CLK-
 HDMI2_DDC_SCL << HDMI2_DDC_SCL
 HDMI2_DDC_SDA << HDMI2_DDC_SDA
 HOTPLUG2 << HOTPLUG2
 HDMI_CEC << HDMI_CEC

HDMI2_D2+ << HDMI2_D2+
 HDMI2_D2- << HDMI2_D2-
 HDMI2_D1+ << HDMI2_D1+
 HDMI2_D1- << HDMI2_D1-
 HDMI2_D0+ << HDMI2_D0+
 HDMI2_D0- << HDMI2_D0-
 HDMI2_CLK+ << HDMI2_CLK+
 HDMI2_CLK- << HDMI2_CLK-
 HDMI2_DDC_SCL << HDMI2_DDC_SCL
 HDMI2_DDC_SDA << HDMI2_DDC_SDA
 HOTPLUG2 << HOTPLUG2
 SV_DET_HDMI_2 << SV_DET_HDMI_2

HDMI_CEC << HDMI_CEC

Mark on board
HDMI1

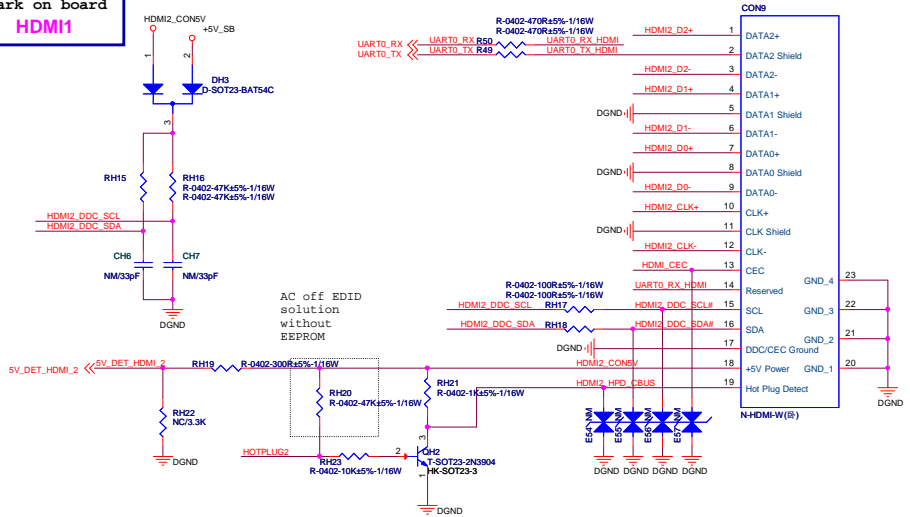

Title	RTD2871 Demo Board		
Size	Document Number		Rev
C	HDMI2		1.0
Date:	Thursday, February 28, 2019	Sheet	18 of 30

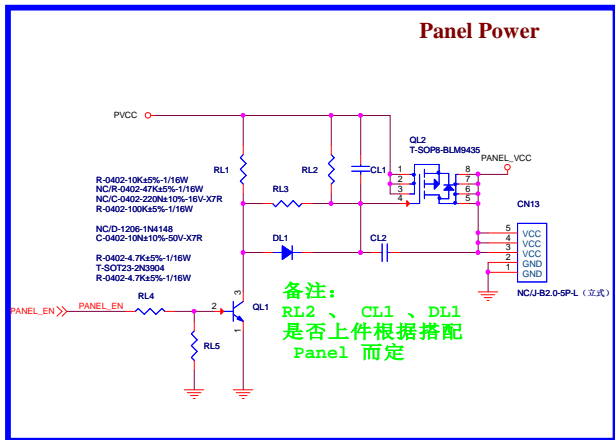
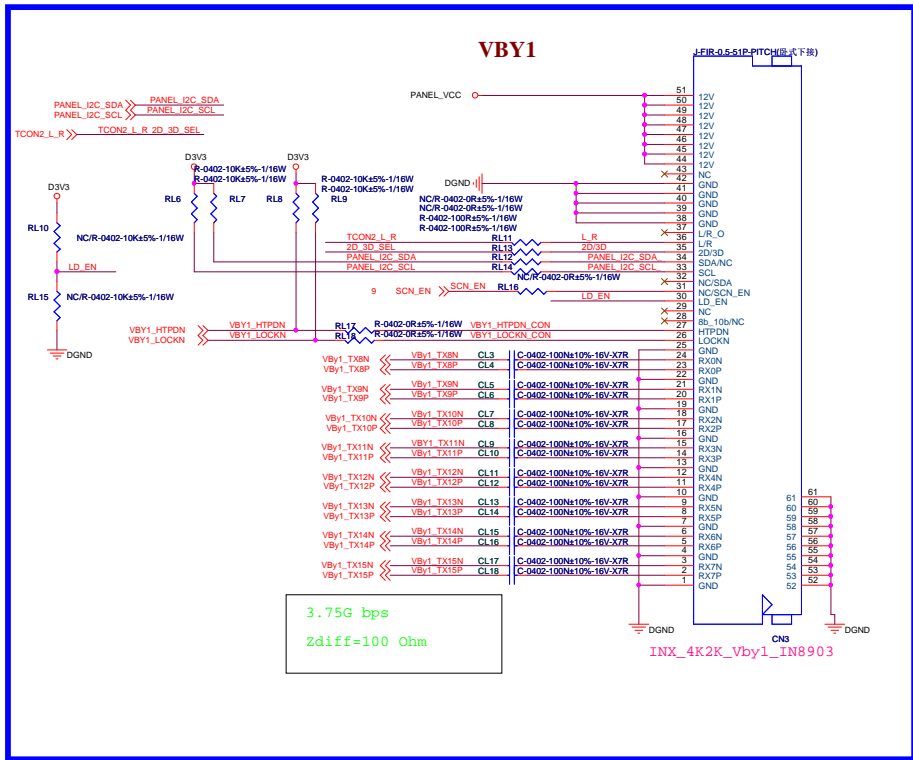

Title		RTD2871 Demo Board	
Size	Document Number	Rev	1.0
C	Panel Interface		
Date:	Monday, March 11, 2018	Sheet	19 of 30

EMMC 5.0

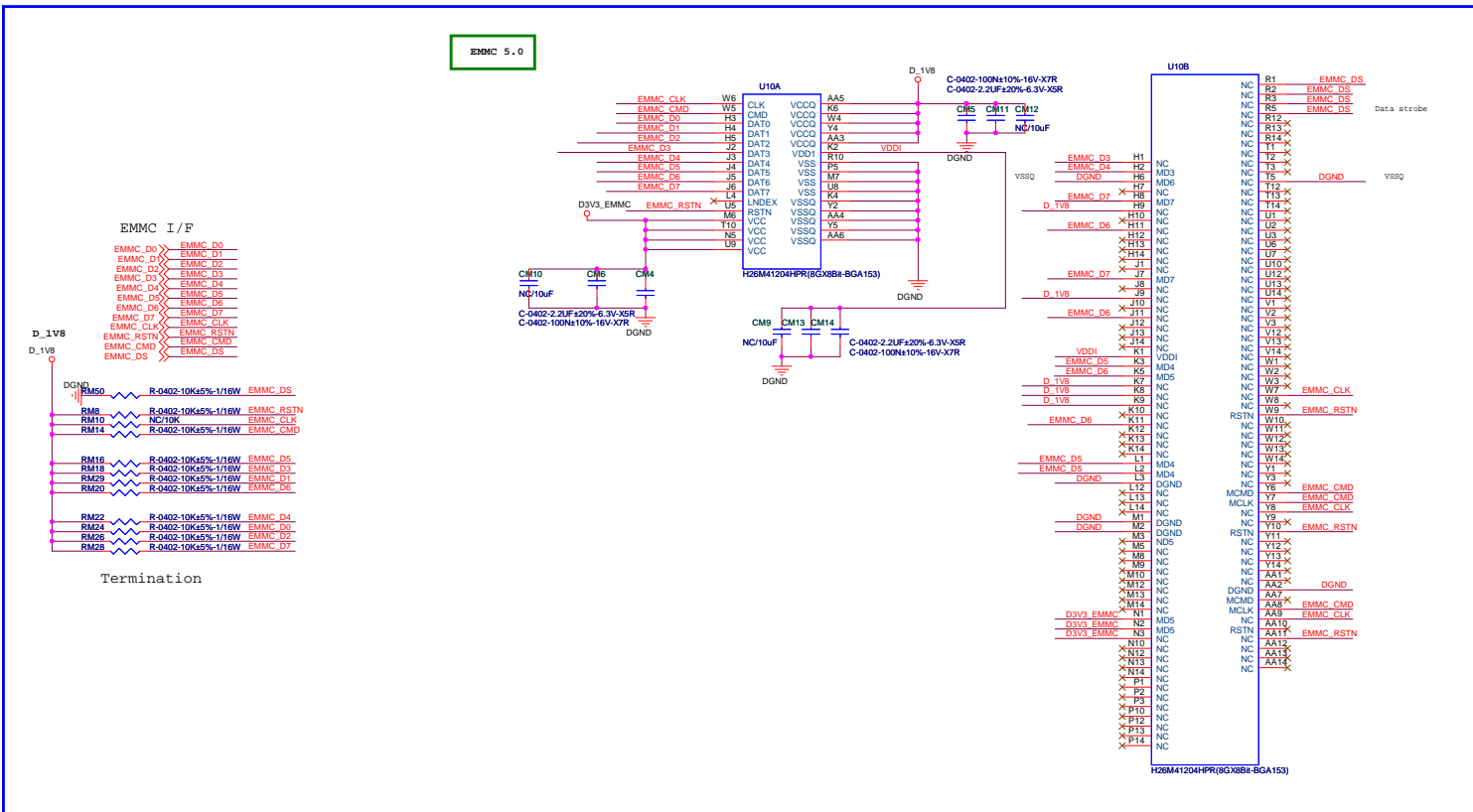

EMMC I/F

- EMMC_D0 > EMMC_D0
- EMMC_D1 > EMMC_D1
- EMMC_D2 > EMMC_D2
- EMMC_D3 > EMMC_D3
- EMMC_D4 > EMMC_D4
- EMMC_D5 > EMMC_D5
- EMMC_D6 > EMMC_D6
- EMMC_D7 > EMMC_D7
- EMMC_CLK > EMMC_CLK
- EMMC_RSTN > EMMC_RSTN
- EMMC_CMD > EMMC_CMD
- EMMC_DS > EMMC_DS

Termination

Title	RTD2871 Demo Board	
Size	Document Number	Rev
C	NAND/SP/EMMC/EEPROM	
Date:	Thursday, February 28, 2019	Sheet 20 of 30

Main Chip <->
 <-> <->
 <-> <->
 <-> <->

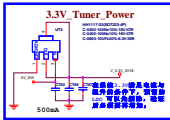
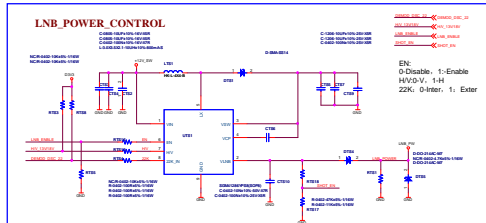
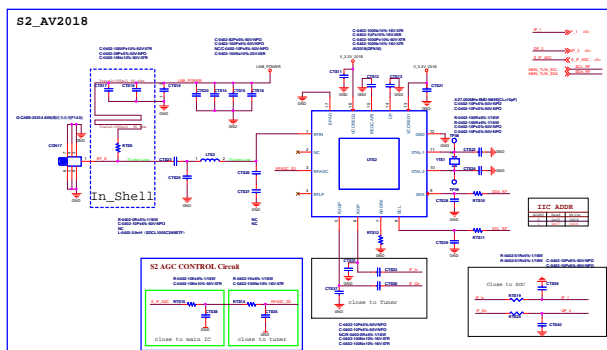
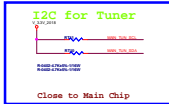
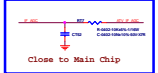
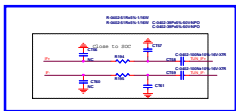
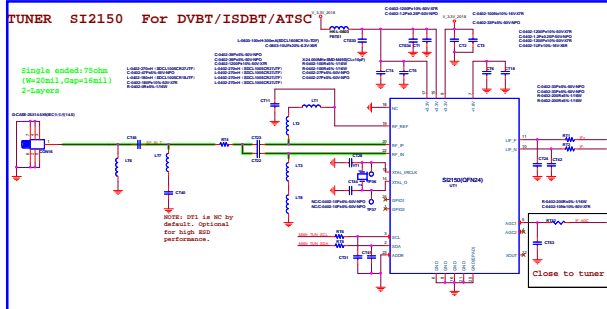

U2P2_DM
U2P2_DP
U2P2_DM
U2P2_DP
U2P2_DM
U2P2_DP

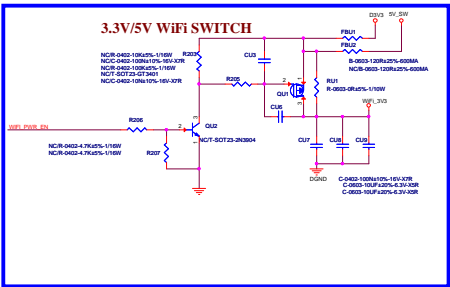
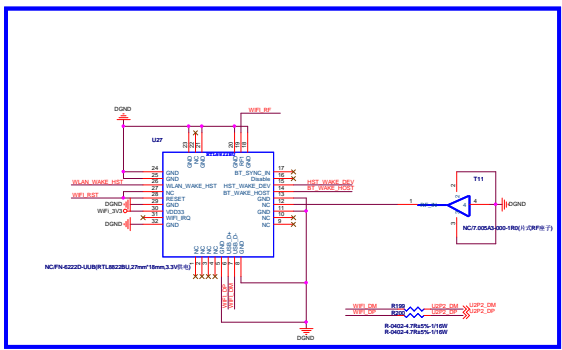
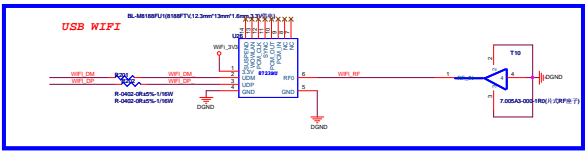
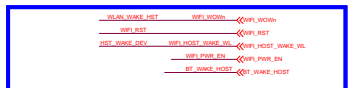
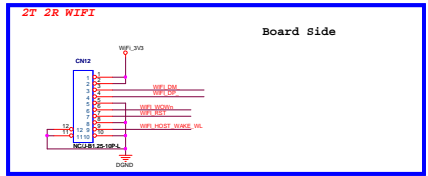
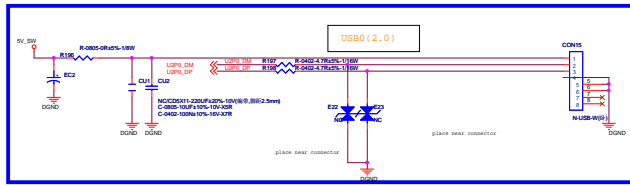

RTD02P1 DevKit Board	
Doc ID	Document Number
100_210	100_210
Rev	Revision
1.0	1.0
Date	Published
February 14, 2019	28 of 30

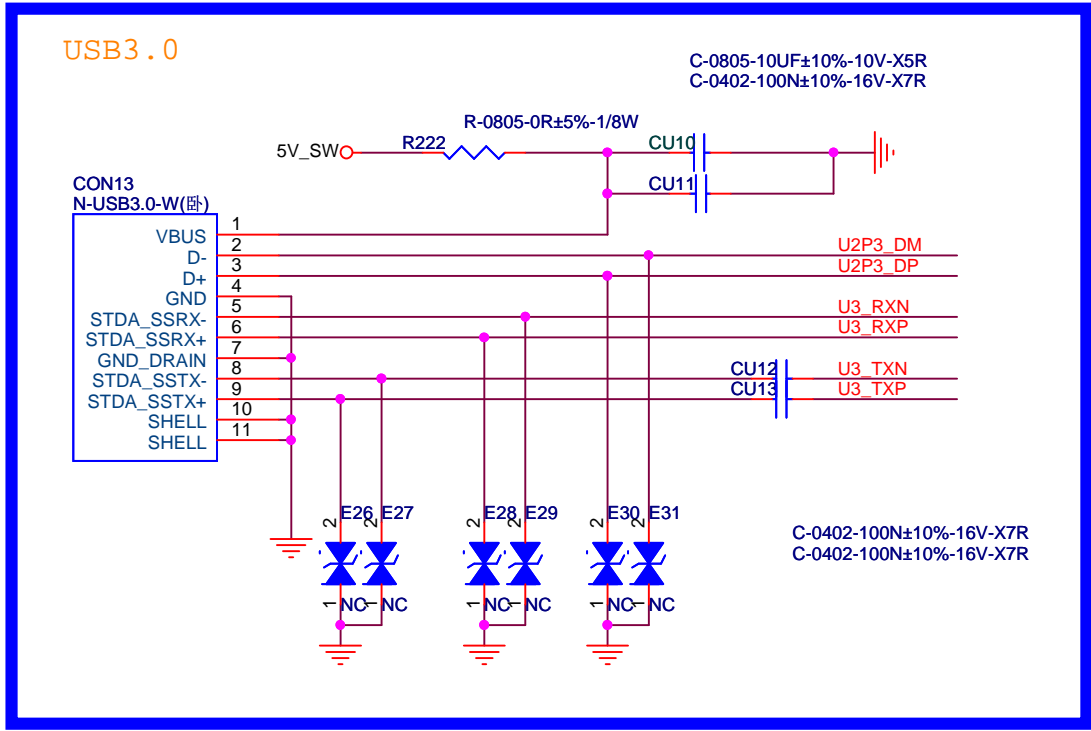
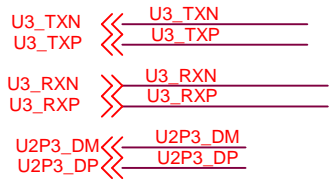

Title		
RTD2871 Demo Board		
Size	Document Number	Rev
A	USB_3.0_TYPE C	1.0
Date:	Thursday, February 28, 2019	Sheet 23 of 30

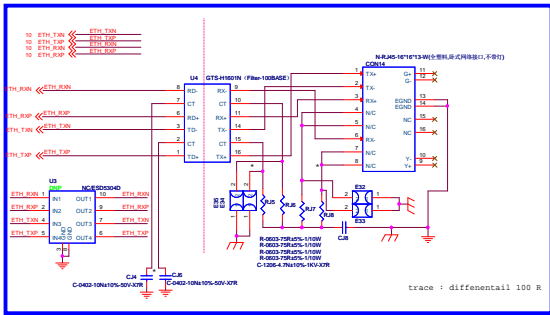

REV		RTD02P1 Demo Board	
ID		Document Number	Rev
Date		Doc ID: RTD02P1	1.0
Date		Thursday, February 28, 2019	Sheet 24 of 30

TPI_DATA3	TPI_DATA3	PC_DATA0	PC_DATA0
TPI_DATA4	TPI_DATA4	PC_DATA1	PC_DATA1
TPI_DATA5	TPI_DATA5	PC_DATA2	PC_DATA2
TPI_DATA6	TPI_DATA6	PC_DATA3	PC_DATA3
TPI_DATA7	TPI_DATA7	PC_DATA4	PC_DATA4
		PC_DATA5	PC_DATA5
		PC_DATA6	PC_DATA6
		PC_DATA7	PC_DATA7
		PC_DATA8	PC_DATA8
		PC_DATA9	PC_DATA9
PC_IORD#	PC_IORD#	PC_CE1#	PC_CE1#
PC_IOWR#	PC_IOWR#	PC_OE#	PC_OE#
TPO_SYNC	TPO_SYNC	PC_WE#	PC_WE#
TPO_DATA0	TPO_DATA0	PC_IRG#	PC_IRG#
TPO_DATA1	TPO_DATA1		
TPO_DATA2	TPO_DATA2		
TPO_DATA3	TPO_DATA3		
		TPO_VALID	TPO_VALID
		TPO_CLK	TPO_CLK
TPO_DATA4	TPO_DATA4	PC_ADDR14	PC_ADDR14
TPO_DATA5	TPO_DATA5	PC_ADDR13	PC_ADDR13
TPO_DATA6	TPO_DATA6	PC_ADDR12	PC_ADDR12
TPO_DATA7	TPO_DATA7	PC_ADDR11	PC_ADDR11
TPI_CLK	TPI_CLK	PC_ADDR10	PC_ADDR10
PC_RST	PC_RST	PC_ADDR9	PC_ADDR9
PC_WAIT#	PC_WAIT#	PC_ADDR8	PC_ADDR8
		PC_ADDR7	PC_ADDR7
PC_REG#	PC_REG#	PC_ADDR6	PC_ADDR6
TPI_VALID	TPI_VALID	PC_ADDR5	PC_ADDR5
TPI_SYNC	TPI_SYNC	PC_ADDR4	PC_ADDR4
TPI_DATA0	TPI_DATA0	PC_ADDR3	PC_ADDR3
TPI_DATA1	TPI_DATA1	PC_ADDR2	PC_ADDR2
TPI_DATA2	TPI_DATA2	PC_ADDR1	PC_ADDR1
PC_CD#	PC_CD#	PC_ADDR0	PC_ADDR0
PC_INPACK#_CON	PC_INPACK#_CON		

TPO : From Scalar (From demod for Europe)
 TPI : To Scalar
 PC : To Scalar

Mark on board
 PC CARD

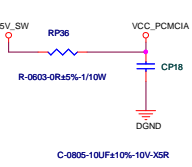
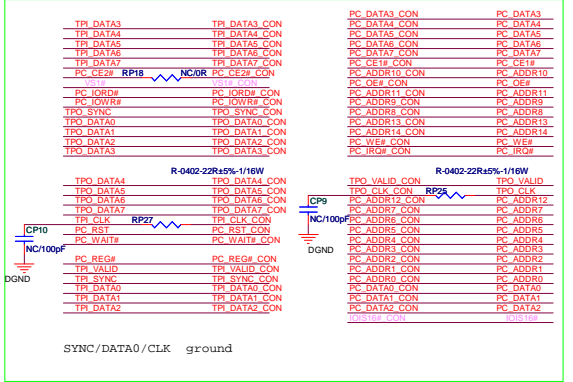
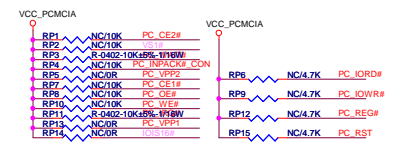
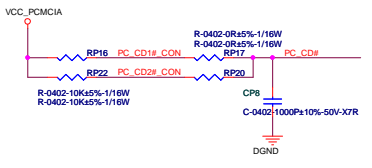
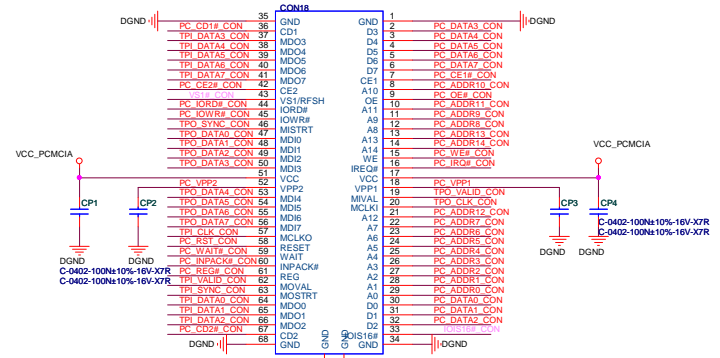

Title	RTD2871 Demo Board	
Size	Document Number	Rev
C	PCMCIA (CI CARD)	1.0
Date:	Thursday, February 28, 2019	Sheet 26 of 30

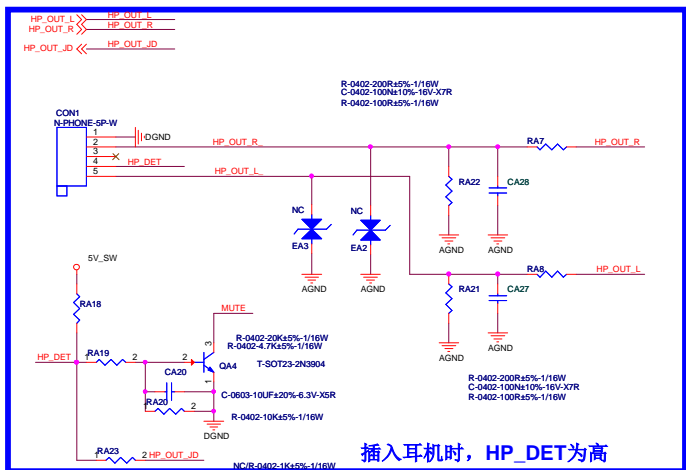
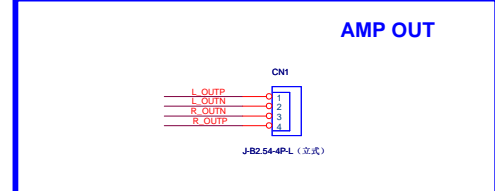
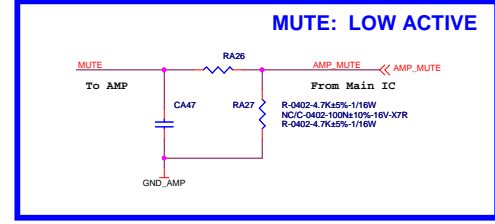
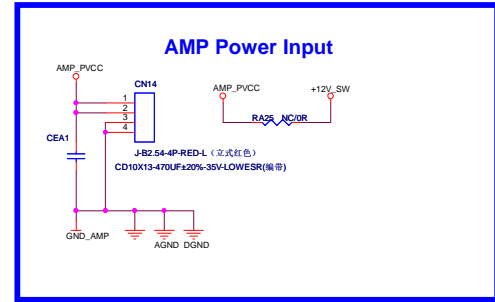
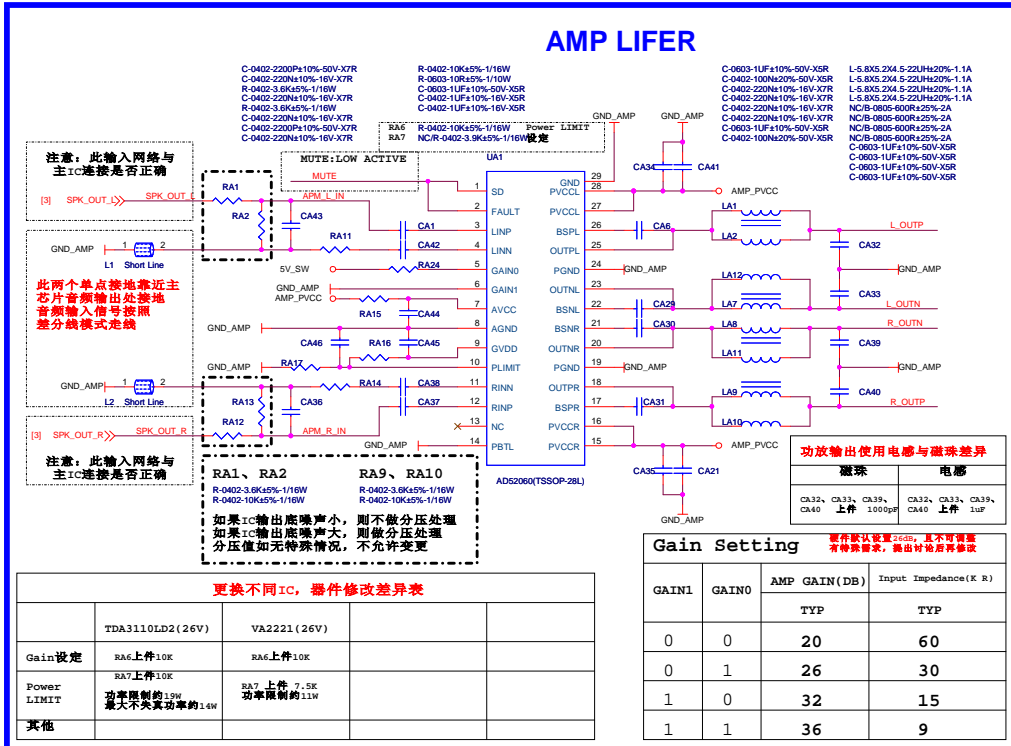

Title	RTD2871 Demo Board		
Size	Document Number	Rev	
C	I2S OUTPUT Amp	1.0	
Date:	Thursday, March 14, 2019	Sheet	26 of 30

Make on board
Keypad

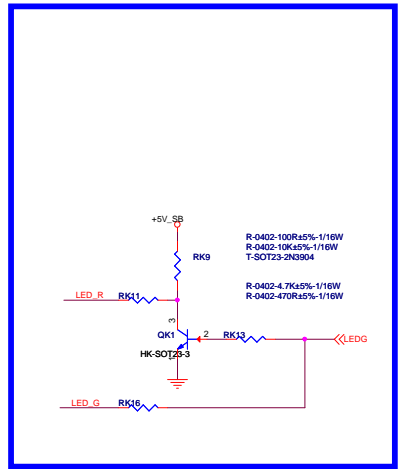
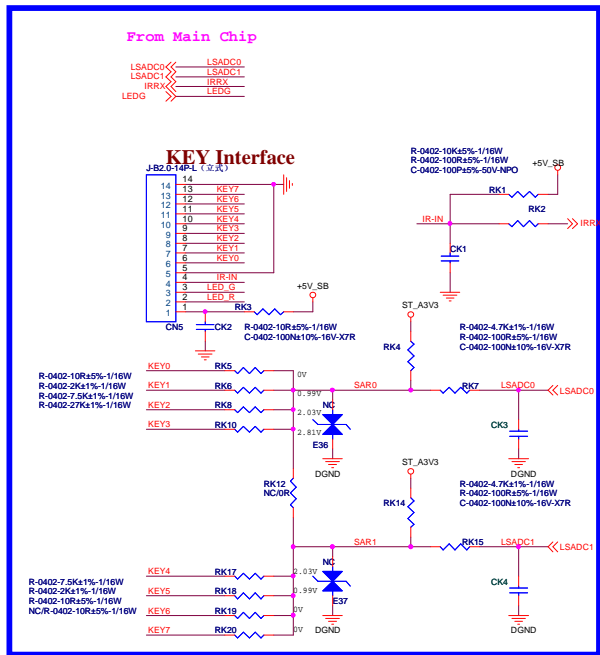

Title	RTD2871 Demo Board	
Size	Document Number	Rev
C	KeyLED/IDA	
Date	Thursday, February 28, 2019	Sheet 27 of 30